

GMA81/83/84/88

Compact Controllers for all Transmitters



- Compact controller for easy wall mounting
- Simple operation
- Flexible for all detection tasks
- Re-configurable by user

Worldwide Supplier Of Gas Detection Solutions



Fixed Gas Controller for Wall Mounting



GMA88 A

The compact gas controller

The GMA81, GMA83, GMA84 and GMA88 are compact gas monitoring controllers for wall mounting. Together with GfG's powerful and robust transmitters the GMAs form complete systems for monitoring of gas hazards for many applications. The GMA81 is a single channel controller for one detection point. Low cost of ownership for several detection points is provided by the GMA83 for up to 3 transmitters, the GMA84 for max. 4 transmitters, or the GMA88, which allows monitoring of up to 8 channels simultaneously.

Easy wall mounting

The robust GMA housings can be easily mounted to the wall. You do not need cabinets or additional enclosures. The small size allows space saving installation. The terminal bars for electrical connections are easily accessible behind a cover at the front. The casing is robust and splash water proof (IP54).

Monitoring more than 500 gas hazards

GfG's gas monitoring systems allow detection of more than 500 gases. You can adapt the GMA settings to any monitoring task for individual and cost effective solution of your specific requirements.

Combustible gases

Where combustible gases may build up explosive concentrations, GfG offers a variety of sensors and transmitters.

Toxic gases

Specially selected GfG transmitters provide reliable monitoring of areas, where toxic gases and vapors may be present.

Oxygen

GfG transmitters ensure reliable protection from hazards caused by oxygen deficiency or surplus.

Detecting - Recognizing - Warning

Once the gas concentration at the transmitter exceeds a certain threshold, the GMA recognizes the danger and triggers an alarm. The controller provides 3 threshold alarms, which can be programmed individually. Adjustable alarm delay eliminates false alarms. Every threshold is adjustable within the detection range and can be latching / non-latching and resettable / non-resettable. This allows the best possible adaptation of the controller to your specific detection task. All settings can be changed, even at a later stage.

Quick reaction means increased safety

Every GMA provides 4 voltage-free relays for the 3 alarms and for fault warning. The relays may be used for controlling external alarm devices like beacons and buzzers or, e.g. by closing solenoid valves or turning a fan on, they can introduce specific counter measures to prevent dangers from gases or vapors. Every relay can be either a normally closed (NC) or normally open (NO) contact and works in either closed or open circuit operation. This flexibility allows the GMA to meet individual requirements and to offer a safe solution of specific gas detection problems.

Alarm models:

**GMA81 A / GMA83 A /
GMA84 A / GMA88 A**

These models provide integrated audible and visual alarm devices. A bright flashlight on top of the GMA indicates a gas alarm. A buzzer is built-in additionally, thus saving space and wiring efforts. Of course these models include the 4 voltage-free relays, which are standard for the GMA controllers.

Memory

The peak or minimum memory of the GMA81 allows the exact determination of a gas hazard once the alarm was triggered. The GMA stores the peak or the minimum measurement value. Just touch a key to read the value from the LED display.

„Watch Dog“ as per CENELEC standards

The independent surveillance unit (watch dog) of the GMA constantly checks the functions of the microprocessor, parameter memory, circuitry and transmitters. The GMAs comply to EN 50271.

Linearized display

A 3-digit LED display indicates the linearized measurement values. The multi-channel models GMA83, GMA84 and GMA88 provide an extra channel display for exact allocation of values. Additional LEDs inform about operational status, alarm or failure.

Fixed Gas Controller for Wall Mounting

Touch key check

Touch keys allow comprehensive checks of the GMA functions. A separate relay check prevents incidental alarm activation during testing. Just push a button to read the sensor signals of the connected transmitters from the display, i.e. you do not need an external meter for calibration and function test.

Completely configurable

The GMAs are supplied pre-configured to your requirements. Modifications, however, can be easily done: The keypad allows the user to change alarm thresholds and functions even at a later stage. Just connect a PC or a laptop to re-configure the GMA completely.



GMA83

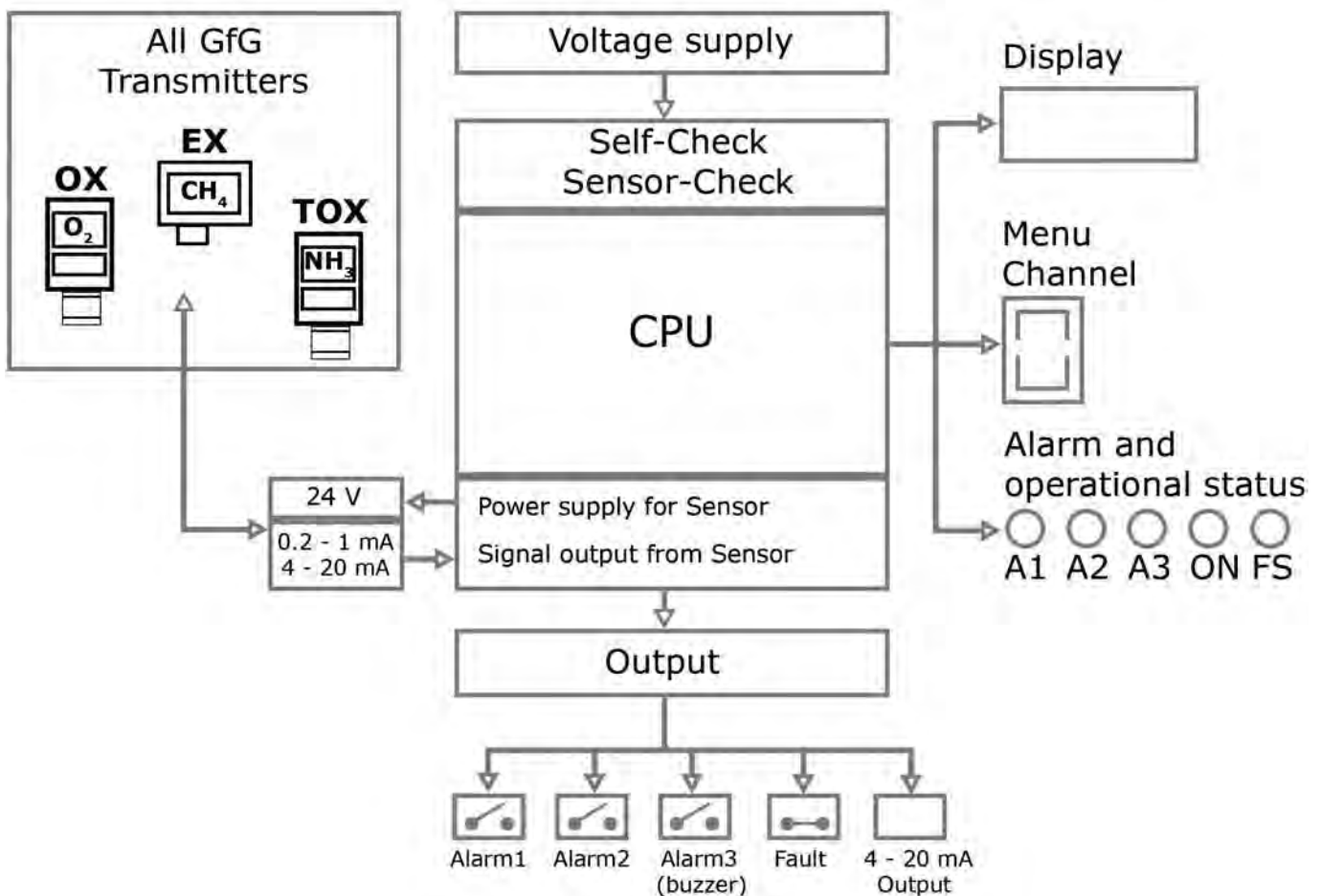

Technical Data

GMA81 / GMA83 / GMA84 / GMA88

Gas:

Depending on transmitter:
Combustible and toxic gases and vapors, oxygen

Detection range:

Depending on requirement:
ppm, % LEL, Vol.-%

Ambient temperature:

-10°C .. +55°C

Power supply:

230 V AC

Power consumption:

Max. 4 W, normal 2 W

Input signal:

0,2 .. 1 mA / 4 .. 20 mA

Alarm functions:

Exceeding / falling below
Latching / non-latching
Resettable / non-resettable
Adjustable hysteresis
Alarm delay 0 .. 2 min.
De-activation variably adjustable
Alarm allocation for GMA84
and GMA 88

Relay outputs:

4 voltage-free relay outputs for alarm
and fault, NC contacts, NO contacts,
change-over contacts
Load: 1000 VA, 5 A

Display:

3-digit LED display for linearized
measurement values, service
1 LED green – Operation
1 LED yellow – Fault
3 LEDs red – Alarm
Indication of peak and minimum
values

Output signal:

Linearized signal 4 .. 20 mA (GMA81)

Function keys:

4 keys for all functions, e.g. alarm
thresholds, calibration, function and
relay test

Calibration:

Automatic zeroing, calibration by
means of measurement value
memory

Enclosure:

130 x 185 x 95 mm (WxHxD)
IP54, splash water proof

Installation:

Easy wall mounting

CE-Certificate

electromagnetic resistance
(directive 89/336/EWG)

EC Type Examination Certificate (GMA81):

ⓂII (2)G BVS 03 ATEX G 006 X

Function test (GMA81):

PFG-No. 41300600 P

Ordering Information:

Single channel models

GMA81
GMA81 A with integrated alarm

3-channel models

GMA83

4-channel models

GMA84
GMA84 A with integrated alarm

8-channel models

GMA88
GMA88 A with integrated alarm

Accessories:

Buzzer
Siren
Flashlight
Beacon

	GMA81	GMA83	GMA84	GMA88
Number of Transmitters	1	up to 3 transmitters of same type	up to 4 transmitters of same type	up to 8 or two groups of 4 identical transmitters
Alarms	3 threshold alarms, adjustable within detection range, GMA81 A with integrated lamp and buzzer	Individual alarm for every transmitter	3 threshold alarms, adjustable within detection range, alarm allocation in display, GMA84 A with integrated lamp and buzzer	3 threshold alarms, adjustable within detection range, alarm allocation in display, GMA88 A with integrated lamp and buzzer
Dimensions W x H x D (mm)	Normal: 130 x 209 x 95 GMA81 A: 135 x 247 x 95	256 x 216 x 123	Normal: 256 x 216 x 123 GMA84 A: 256 x 254 x 123	Normal: 256 x 216 x 123 GMA88 A: 256 x 254 x 123



GfG Headquarters
Klönnestrasse 99
44143 Dortmund • Germany
Phone: +49 / (0)231 - 564 000
info@gfg-mbh.com • www.gasmessung.de

GfG Europe
Great Dunmow
Essex CM6 1XG • United Kingdom
Phone: +44 / (0)1371 - 874 447 • Fax: +44 / (0)1371 - 879 904
info@gfgeurope.com • www.gfgeurope.com